

BA343

Dual-channel preamplifier (with independent ALCs)

The BA343 is a dual-channel high-gain, low-noise preamplifier with an independent automatic level controller (ALC) on each channel.

It is particularly suitable for variable-monitor system stereo cassette recorders. It has a large driver capability and it is designed to reduce the pop noise that occurs during power-up. There is a good balance between the left and right channels for the gain and ALC.

Features

- available in DIP16 package
- wide range power supply (4.5 ~ 12 V)
- high open-loop gain (73 dB)
- low distortion (0.1%)
- low noise ($0.8 \mu V_{rms}$)
- high output drive ($0.8 \mu V_{rms}$ at $V_{CC} = 8.0 V$, $R_L = 1000 \Omega$)
- output voltage is proportional to input voltage
- uniform power on muting characteristics between channels on power up
- pin arrangement is symmetrical to allow simple PCB design

Applications

- stereo cassette tape recorder
- stereo cassette deck
- home stereo
- music centers

Dimensions (Units : mm)

BA343 (DIP16)

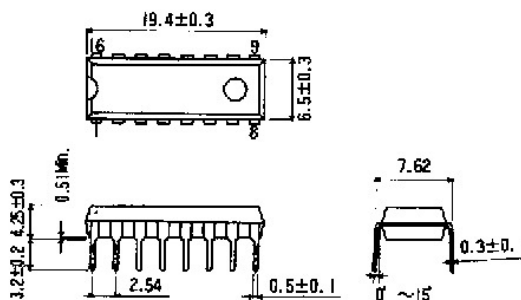

Block diagram

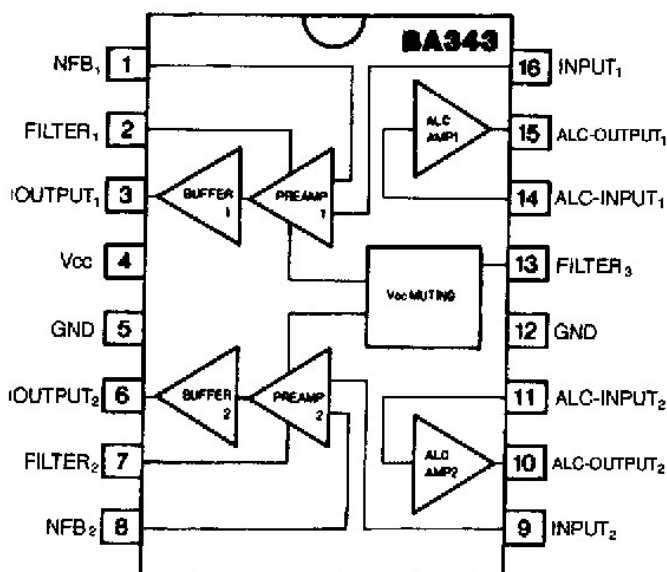

Circuit diagram

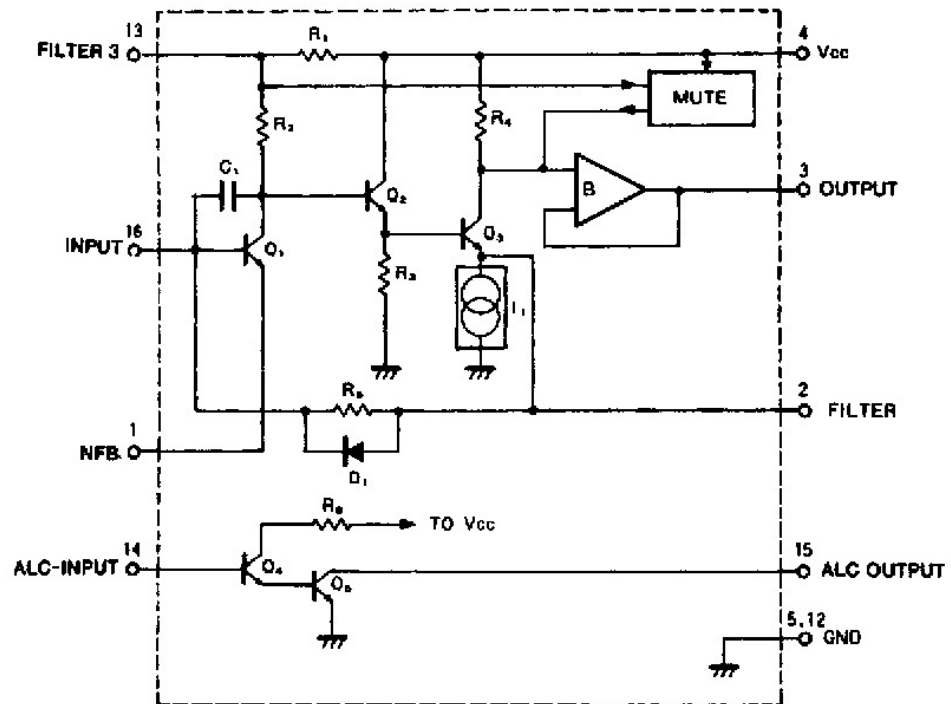

The above diagram shows a half channel of the BA343

Absolute maximum ratings ($T_a = 25^\circ\text{C}$)

Parameter	Symbol	Limits	Unit	Conditions
Power supply voltage	V_{CC}	12	V	
Power dissipation	P_d	600	mW	Reduce power by 10.0 mW for each degree above 25°C
Operating temperature	T_{opr}	$-25 - +75$	$^\circ\text{C}$	
Storage temperature	T_{stg}	$-55 - +125$	$^\circ\text{C}$	

Electrical characteristics ($T_a = 25^\circ\text{C}$, $V_{CC} = 12\text{ V}$)

Parameter	Symbol	Min	Typical	Max	Unit	Conditions
Quiescent current	I_Q	5.0	8.5	14.0	mA	$V_{IN} = 0\text{ V}_{rms}$
Open loop voltage gain	G_{VO}	60	73		dB	$V_{IN} = -75\text{ dBm}$
Maximum output voltage	V_{OM}	1.6	2.3		V_{rms}	THD = 1.0%
Total harmonic distortion	THD		0.1	0.2	%	$V_O = 0.3\text{ V}_{rms}$
Input conversion noise voltage	V_{NIN}		0.8	2.2	μV_{rms}	$R_G = 2.2\text{ k}\Omega$, BPF: 30 Hz – 20 kHz
Input resistance	R_{IN}	90	140		$\text{k}\Omega$	$V_{IN} = 5\text{ mV}_{rms}$
ALC-channel balance	CB_{ALC}	-1.5	0	+1.5	dB	$V_{IN} = -20\text{ dBm}$

BA343 Preampifier

Figure 1 Test circuit

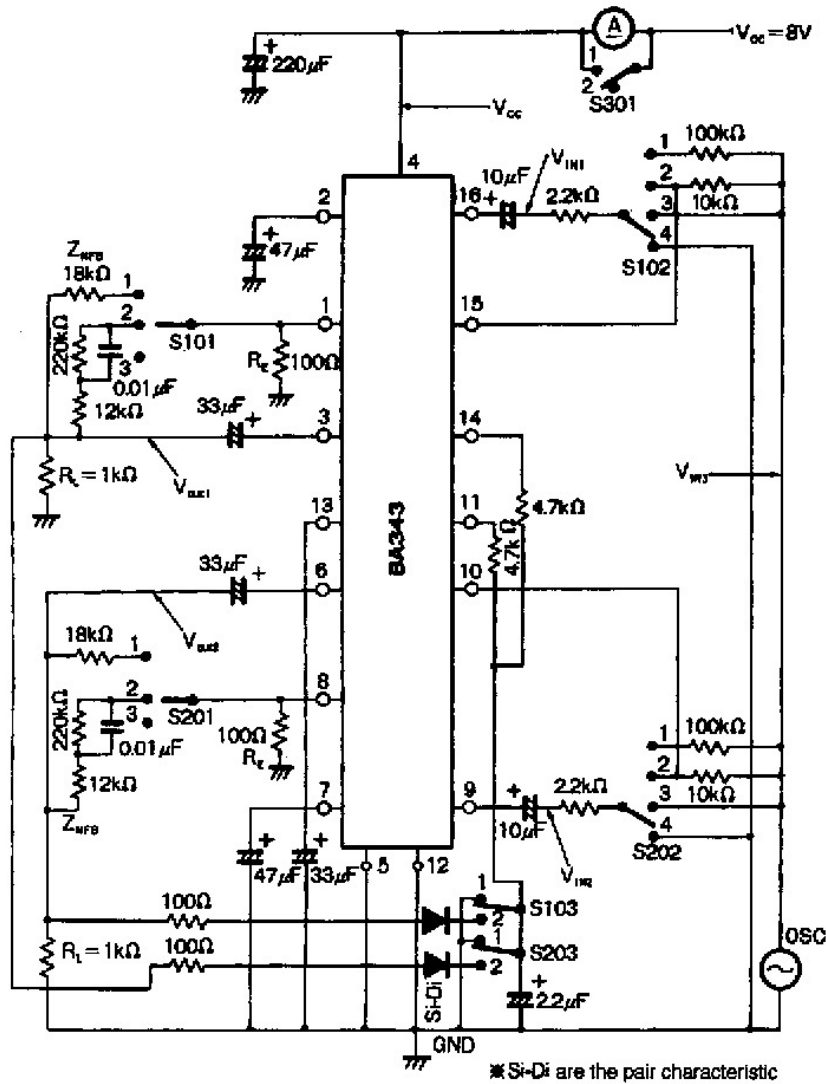

Table 1 Switch setting for test circuit

Parameter	Switch 101	Switch 201	Switch 102	Switch 202	Switch 103	Switch 203	Switch 301
Quiescent current	1	1	4	4	1	1	2
Open loop voltage gain	3	3	3	3	1	1	1
Maximum output voltage	1	1	3	3	1	1	1
Total harmonic distortion	2	2	3	3	1	1	1
Input conversion noise voltage	2	2	4	4	1	1	1
Input resistance	2	2	1/3	1/3	1	1	1
ALC collector voltage	1	1	2	2	2	2	1

BA343 Preamplifier

Figure 3 PCB for application example—solder side

For playback only

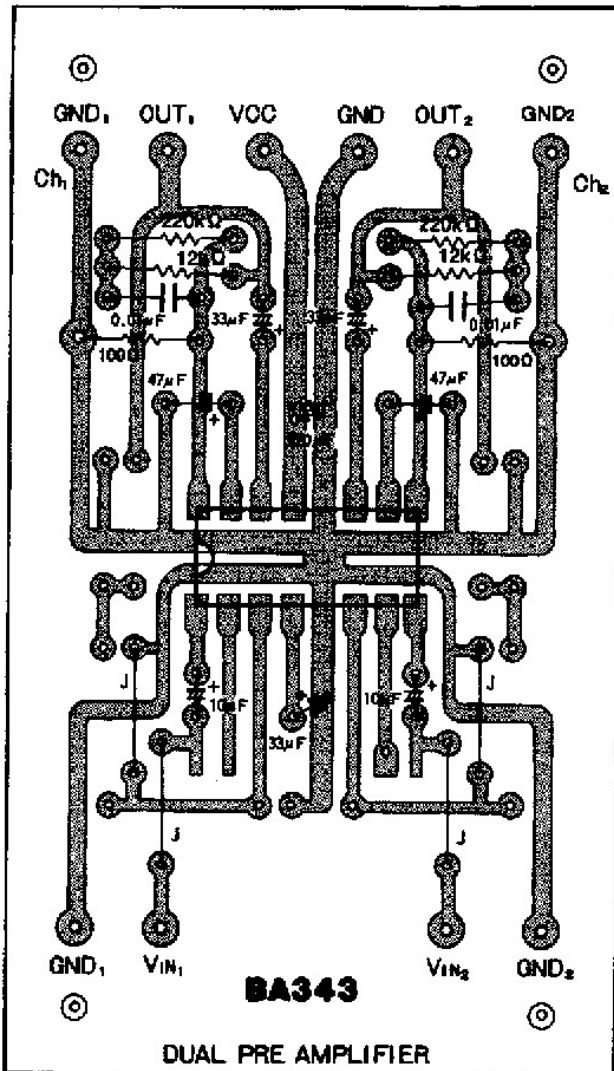

For recording with ALC

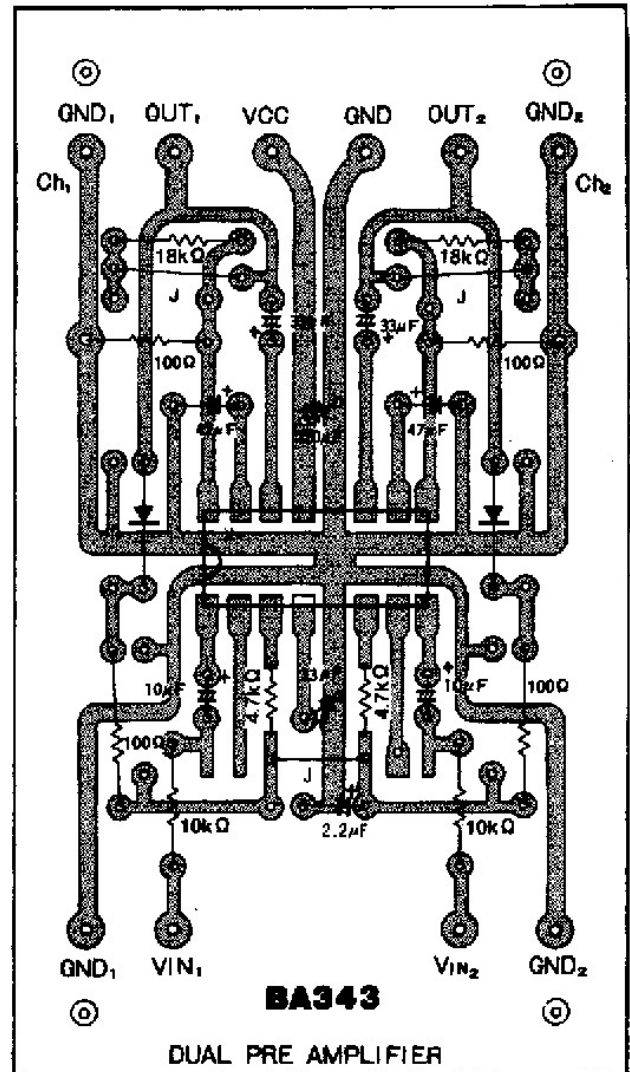

Circuit operation (see Circuit diagram and application example, Figure 2)

3-stage direct connection preamplifier

As shown in the circuit diagram, the 3-stage direct connection preamplifier is configured from transistors Q₁, Q₂ and Q₃, resistors R₂, R₃ and R₄, and the power supply voltage constant current supply, I₁. A bypass capacitor is connected to pin 2. Capacitor C₁ is used to set the treble cut-off frequency. The input signal is connected to the base of transistor Q₁ at pin 16.

Buffer amplifier

For voltage gain, the unit has a buffer amplifier to keep the impedance constant. It is connected to the collector of Q_3 and receives the output signal of the 3-stage direct connection amplifier.

Muting during power-up

The MUTE component switches on when there is a potential difference between pin 4 (V_{CC}) and pin 13 (Filter 3) during power-up. Therefore, the output of the MUTE is connected to the input section of the buffer.

The pop noise at power up is audibly reduced by the mute circuit because it effectively turns off the audio output until pin 4 and pin 13 come up to the same potential.

Ripple filter

R1 is the internal component of the ripple filter. The external capacitor attached to pin 13, with R1 forms the ripple filter. This also serves as a timer for the mute.

Bias circuit

R5 is used to set the bias. It controls the current to the base of Q_1 from pin 2. D_1 is a bypass diode that is used to charge the input coupling capacitor faster.

ALC circuit

The ALC circuit consists of the two Darlington-connected transistors Q_4 and Q_5 . Automatic volume adjustment is made possible by this circuit. The input is connected to the base of Q_4 at pin 14. The output on pin 15 is connected to the collector of transistor Q_5 .

Ground pin

There are two ground systems, one on pin 5 and one on pin 12. Use either connection depending on the board pattern and the application. The aim is to further decrease distortion.

Explanation of external components (See Fig. 9)

Emitter resistor

Between pin 1 (pin 8) and ground. These resistors are used to determine the gain. Use a value of about 100Ω . The gain is determined by the proportion between the impedances of these resistors, the feedback device (NAB), and the (FLAT). When the impedance for the feedback device is Z_{NFB} , the gain is determined as follows:

$$G_{VC} = 20 \log \frac{Z_{NFB}}{R_E}, \text{ for example, if } R_E = 100 \Omega, G_{VC} = 20 \log \left(\frac{18000}{100} \right) = 45 \text{ dB}$$

Filter bypass capacitor

Connected between pin 2 (pin 7) and ground. A 47 μF electrolytic capacitor is ideal. If this value is made too large, bass oscillation will occur. If it is made too small, the bass response may deteriorate.

Output coupling capacitor

This capacitor is used to remove the dc current between pin 3 (pin 6) and the load. A 33 μF electrolytic capacitor is ideal. If this value is made too large or too small, bass oscillation will occur.

Power supply filter capacitor

Connected between pin 4 and ground. It is recommended that a 220 μF electrolytic capacitor is connected to pin 4 to serve as a ripple filter for the power supply and reduce the switching noise. If this capacitor is made too small, it will not effectively isolate the ripples in the power supply and the switching noise at start up will become more audible.

Input coupling capacitor

These capacitors are connected between pin 16 (pin 9) and the signal source.

This capacitor cuts the bias current of the input transistor. A value of 10 μF is best. If this value is made too small, bass oscillation will occur. If it is made too large, switching noise at start up will become more audible.

ALC resistor

These resistors are connected between pin 15 (pin 10) and the input. A 10 $\text{k}\Omega$ resistor is recommended. If the resistance is made too small, the ALC function deteriorates. If the resistance is made too large, it may add noise to the audible output.

Resistance for parallel ALC input

These resistors are connected between pin 14 (pin 11) and the ALC capacitor. Use a resistance of about 4.7 $\text{k}\Omega$.

The ALC difference between channels becomes lower and simultaneous operation is possible.

Ripple filter capacitor

This capacitor is connected to pin 13. It is used both to control the ripple currents and as part of the timing circuit for the power on mute circuit.

Electrical characteristic curves

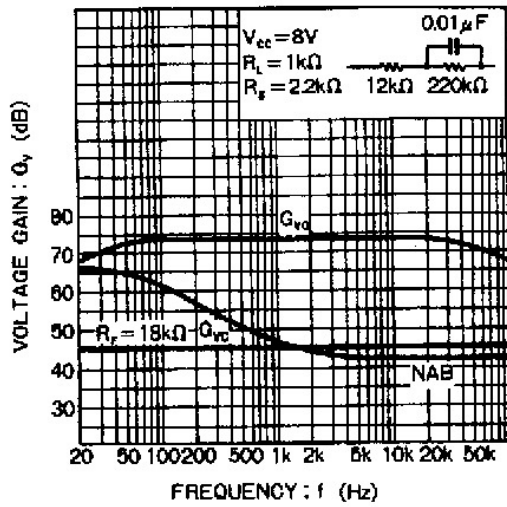

Figure 4

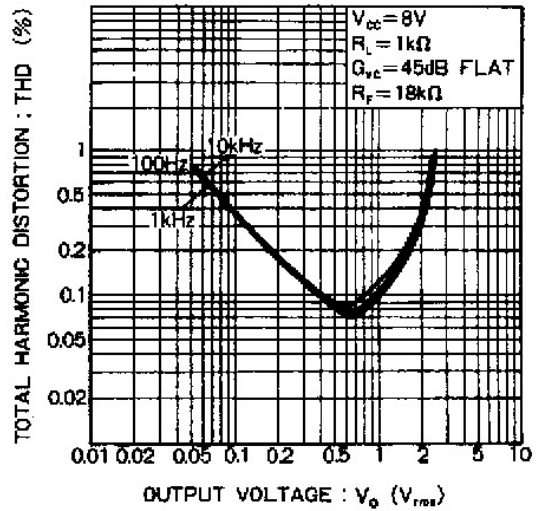

Figure 5

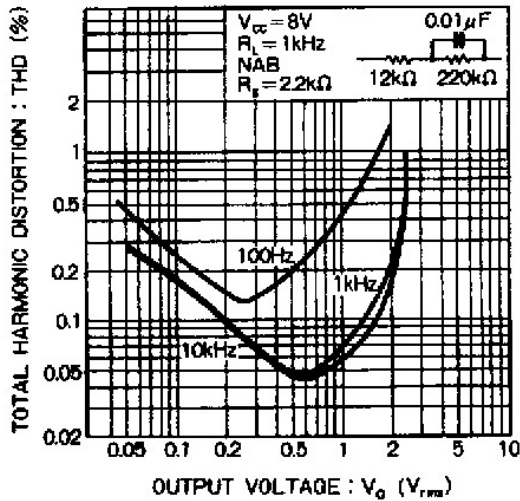

Figure 6

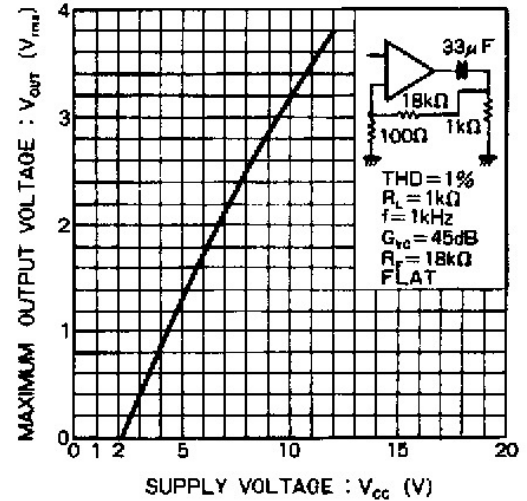

Figure 7

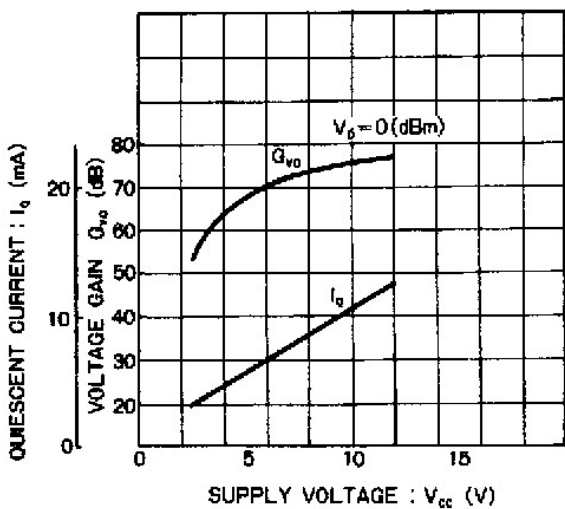

Figure 8

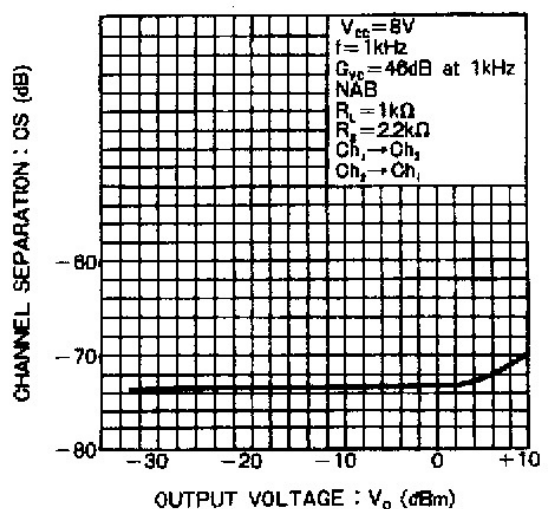

Figure 9

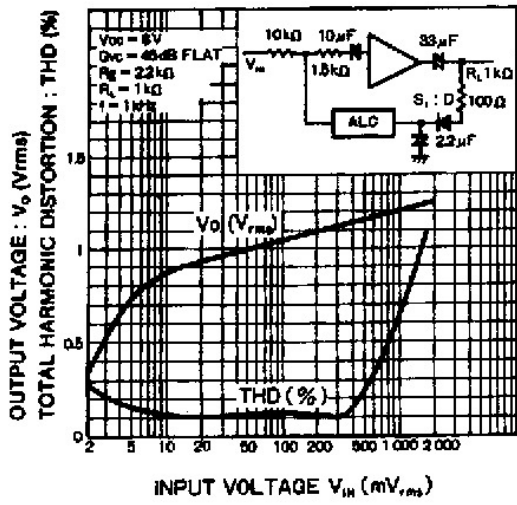

Figure 10

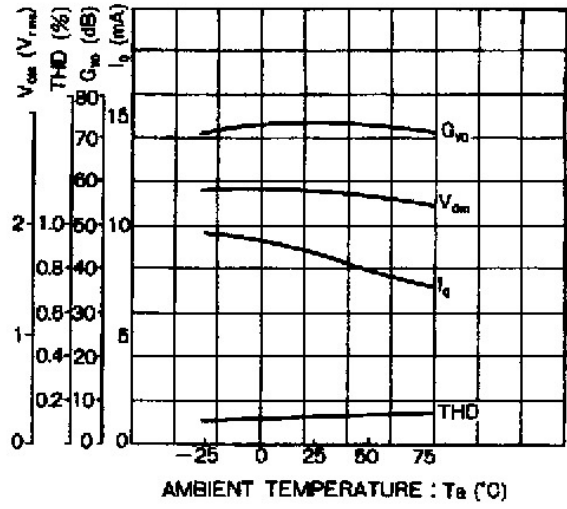

Figure 11